

DRILLING-MILLING HEAD, ANGLE ADJUSTABLE (0-90°)  
UNITE' DE PERCAGE RADIALE REGLABLE (0-90°)

BOHR- UND FRAESKOPF WINKELVERSTELLBAR (0-90°)  
UNIDAD PARA FORAR - FRESAR REGULABLE ANGULARMENTE (0-90°)

**UNITA' A FORARE - FRESARE REGOLABILE ANGOLARMENTE (0-90°)**

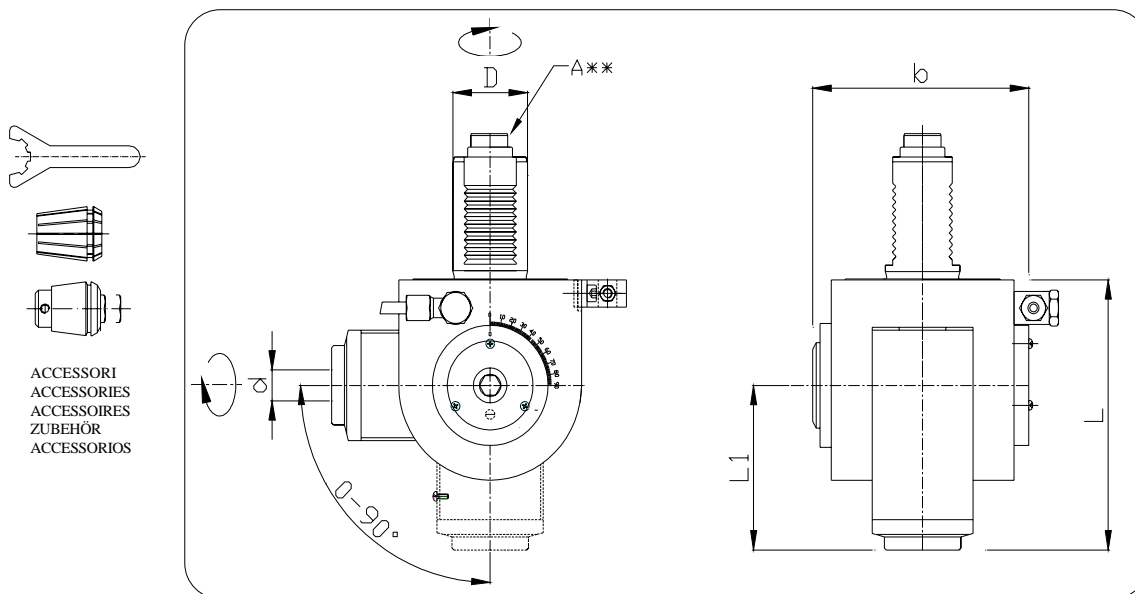

N. Cod.	Dh6	d	L	L1	b	n. Max	n1/n2	Nm	Kg.
TE30E10...	30	1-10 ER16	115	75	92	6000	1:1	10	4,500
HE40E16...	40	1-16 ER25	140	85	116	6000	1:1	25	6,800
HE50E16...	50	1-16 ER25	140	85	116	6000	1:1	25	7,200

A** Dh6	Baruffaldi	Din 1809	Sauter Din 5482
	Ø 16	-	-
Ø 20	...25	...17	...02
Ø 30	...27	...18	...06
Ø 40	...28	...19	...09
Ø 50	...29	...20	...11
Ø 60	...30	...21	...13
Ø 80	-	...22	...15

Esempio / Example:

d = ER25  
Dh6 = Ø 40  
A\*\* = SAUTER DIN 5482  
OMAP TOOLS CODE NR = **HE40E1609**