

DRILLING-MILLING HEAD, ANGLE ADJUSTABLE (0-90°)
UNITE' DE PERCAGE RADIALE REGLABLE (0-90°)

BOHR- UND FRAESKOPF WINKELVERSTELLBAR (0-90°)
UNIDAD PARA FORAR - FRESAR REGULABLE ANGULARMENTE (0-90°)

UNITA' A FORARE - FRESARE REGOLABILE ANGOLARMENTE (0-90°)

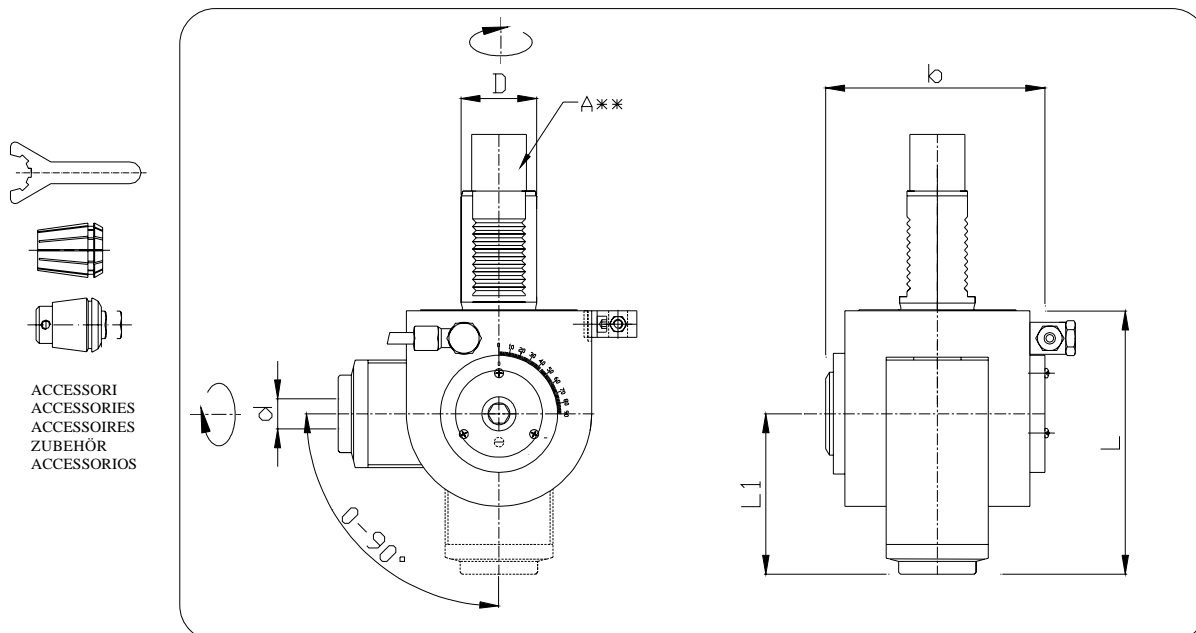

N. Cod.	Dh6	d	L	L1	b	n. Max	n1/n2	Nm	Kg.
TE30E1035	30	1-10 ER16	120	76	92	6000	1:1	10	4,600
HE40E1636	40	1-16 ER25	140	85	116	6000	1:1	25	6,800
HE40E1637	40	1-16 ER25	140	85	116	6000	1:1	25	6,800

Drive A** Dh6	TYPE II		TYPE I	
	Ø 30	-	-	...35
Ø 40	-	-	...36	LB300M-LB300MY LU300M-L370M LVT300M-LVT400M
Ø 40	-	-	...37	LB25M-LU25M LB25IIM-LU400 L470M
Ø 50	...39	LB35IIM	...38	LU35M-LB45 LU45