

AXIAL DRILLING AND MILLING HEAD
TÊTE DE PERÇAGE - FRAISAGE AXIALE

AXIAL BOHR -UND FRAESKOPF
UNIDAD PARA FORAR - FRESAR AXIAL

TESTA DI FORATURA - FRESATURA ASSIALE

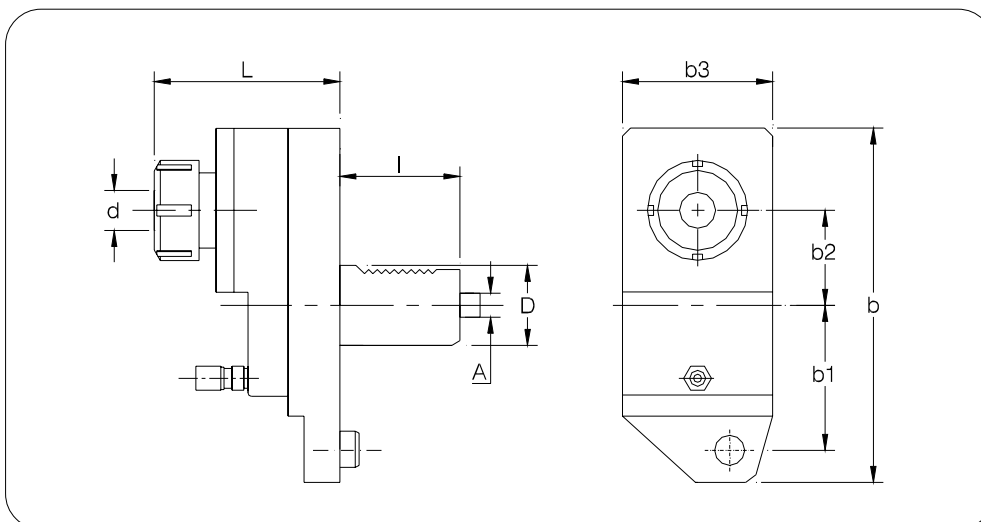

N. Cod.	Dh6	MACHINE	d	A	l	L	b	b1	b2	b3	n. Max	n1/n2	Nm	Kg.
TE40F2045	40	SQ 10 M/C	4-20 ER 32	10	60	94	174	70	50	74	6000	1:1	50	5,000
TE40F2046	40	SQ 15 MY	4-20 ER 32	10	70	94	174	70	50	74	6000	1:1	50	6,000
TE40F2046	40	SQT 250 MS	4-20 ER 32	10	70	94	174	70	50	74	6000	1:1	50	6,000

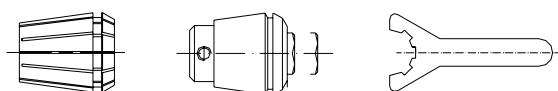

ACCESSORI
ACCESSORIES
ACCESSOIRES
ZUBEHÖR
ACCESORIOS