

AXIAL DRILLING AND MILLING HEAD (DOUBLE)  
TÊTE DE PERÇAGE - FRAISAGE AXIALE (DOUBLE)

AXIAL BOHR -UND FRAESKOPF (DOPPEL)  
UNIDAD PARA FORAR - FRESAR AXIAL (DOBLE)

**TESTA DI FORATURA - FRESATURA ASSIALE PER PINZE (DOPPIA)**

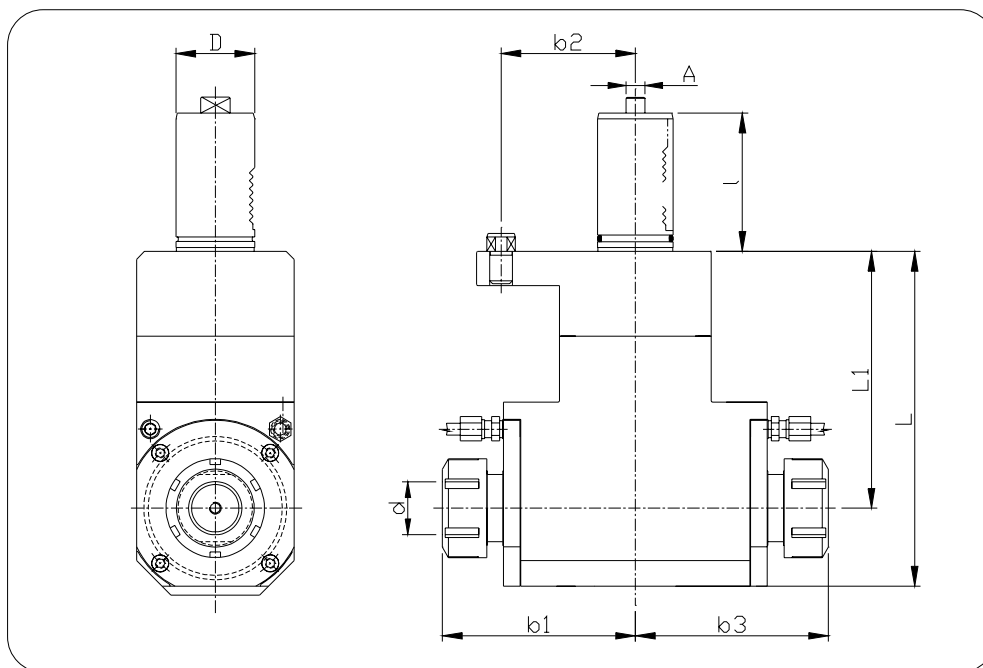

N. Cod.	Dh6	MACHINE	d	A	l	L	L1	b1	b2	b3	n. Max	n1/n2	Nm	Kg.
TE40L2046	40	SQ 15 MY	4-20 ER 32	10	70	169	130	98	70	98	6000	1:1	50	12,000
TE40L2046	40	SQT 250 MS	4-20 ER 32	10	70	169	130	98	70	98	6000	1:1	50	12,000

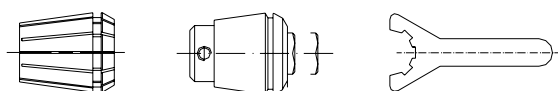

ACCESSORI  
ACCESSORIES  
ACCESSOIRES  
ZUBEHÖR  
ACCESORIOS