

90° DRILLING AND MILLING HEAD (SHORT)
TÊTE DE PERÇAGE - FRAISAGE 90° (COURT)

90° BOHR - UND FRAESKOPF (KURZ)
UNIDAD PARA FORAR - FRESAR 90° (CORTO)

TESTA DI FORATURA - FRESATURA 90° (CORTO)

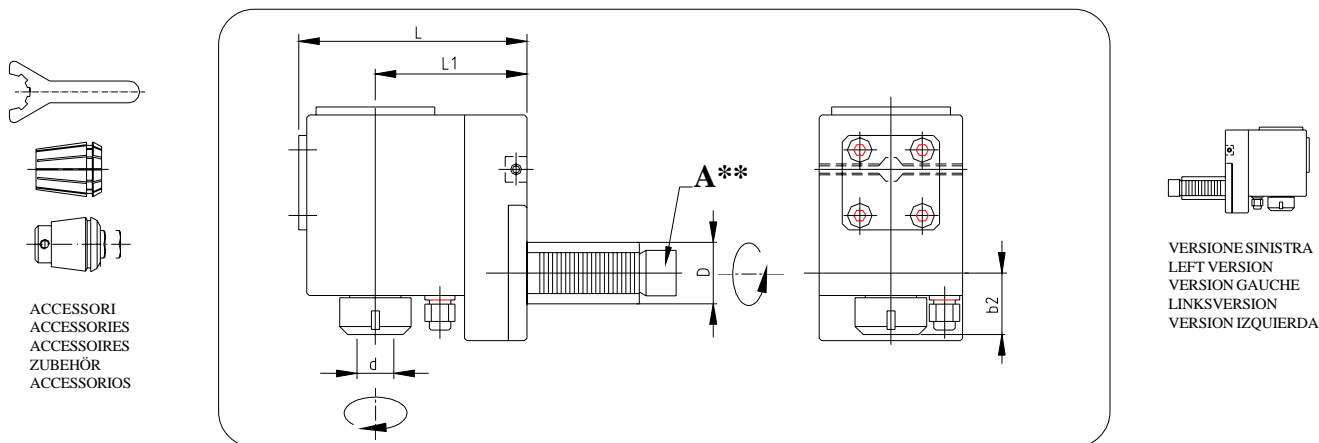

N. Cod.	Dh6	d	L	L1	b2	n. Max	n1/n2	Nm	Kg.
TE16C07...	16	1-7 ER11	70	48	28	6000	1:1	10	1,200
TE20C10...	20	1-10 ER16	70	48	37	6000	1:1	10	1,300
TE30C13...	30	1-13 ER20	106	70	48.5	6000	1:1	25	5,000
TE40C20...	40	4-20 ER32	130	86	40	6000	1:1	50	6,500
TE50C20...	50	4-20 ER32	130	86	40	6000	1:1	50	8,200
TE50C26...	50	6-26 ER40	140	100	45	4500	1:1	50	9,000
TE60C26...	60	6-26 ER40	189	135	70	2000	1:1	100	30,000
TE80C26...	80	6-26 ER40	189	135	70	2000	1:1	100	35,000
TI60C40...	60	BT40	189	135	35	2000	1:1	100	30,000
TI80C40..	80	BT40	189	135	35	2000	1:1	100	35,000

A** / Dh6	Baruffaldi	Din 1809	Sauter Din 5482
Ø 16	-	-	...01
Ø 20	...25	...17	...02
Ø 30	...27	...18	...06
Ø 40	...28	...19	...09
Ø 50	...29	...20	...11
Ø 60	...30	...21	...13
Ø 80	-	...22	...15

Esempio / Example:

d = ER32
Dh6 = Ø 40
A** = SAUTER DIN 5482
OMAP TOOLS CODE NR = TE40C2009