

0° DRILLING AND MILLING HEAD
TÊTE DE PERÇAGE - FRAISAGE 0°

0° BOHR -UND FRAESKOPF
UNIDAD PARA FORAR - FRESAR 0°

TESTA DI FORATURA - FRESATURA 0°

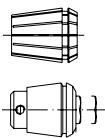
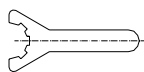

ACCESSORI
ACCESSORIES
ACCESSOIRES
ZUBEHÖR
ACCESORIOS

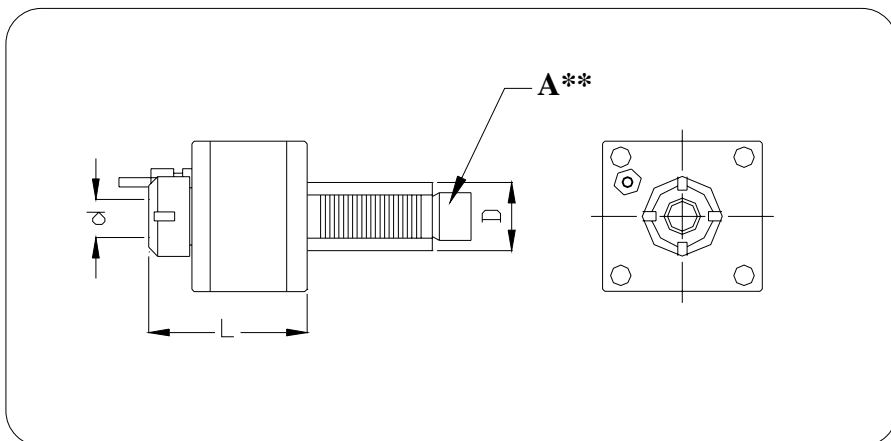

N. Cod.	Dh6	d	L	n. Max	n1/n2	Nm	Kg.
TE16A07...	16	1-7 ER11	82	6000	1:1	15	1,000
TE20A10...	20	1-10 ER16	82	6000	1:1	15	1,100
TE30A13...	30	1-13 ER20	100	6000	1:1	25	2,800
TE40A20...	40	4-20 ER32	110	6000	1:1	60	4,000
TE50A20...	50	4-20 ER32	110	6000	1:1	80	4,800
TE50A26...	50	6-26 ER40	123	4500	1:1	80	4,900
TE60A26...	60	6-26 ER40	180	2000	1:1	100	12,000
TE80A26...	80	6-26 ER40	180	2000	1:1	100	22,000
TI60A40...	60	BT40	140	2000	1:1	100	12,000
TI80A40..	80	BT40	140	2000	1:1	100	22,000

A** / Dh6	Baruffaldi	Din 1809	Sauter Din 5482
Ø 16	-	-	...01
Ø 20	...25	...17	...02
Ø 30	...27	...18	...06
Ø 40	...28	...19	...09
Ø 50	...29	...20	...11
Ø 60	...30	...21	...13
Ø 80	-	...22	...15

Esempio / Example:

d = ER32
Dh6 = Ø 40
A** = SAUTER DIN 5482
OMAP TOOLS CODE NR = TE40A2009