

**COLLET CHUCK (Balanced)**  
**MANDRINS A' PINCES (Balance)**

**PORTAPINZE (Bilanciato)**

**SPANNZANGENAUFNAHMEN (Balanciert)**  
**MANDRILES PORTAFRESAS (Balanzado)**

Collets DIN 6499 (ER)  
 Spannzangen DIN 6499 (ER)  
 Pinces DIN 6499 (ER)  
 Pinze DIN 6499 (ER)

**STANDARD**

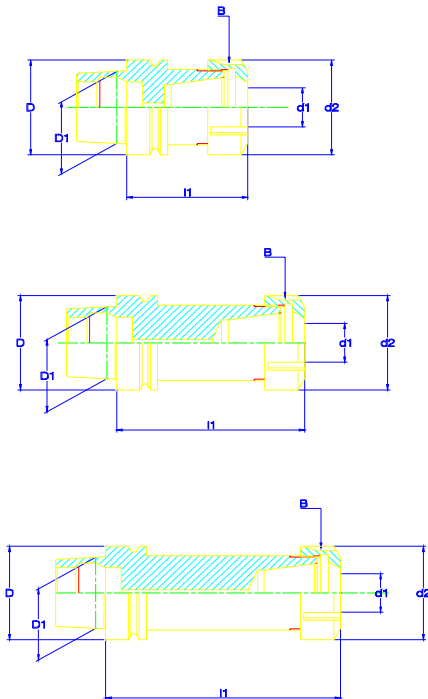

**MINI**

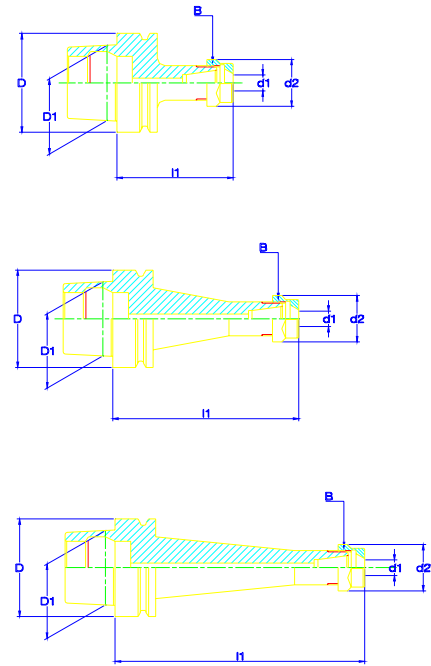

**STANDARD (MAX 25000 RPM)**

N.Cod	HSK	d1	D	D1	d2	l1	B	Note
PE50HF20	50-F	4-20 (ER32)	50	30	50	68	GEA020	
PE50HF26	50-F	4-26 (ER40)	50	30	63	68	GEA026	
PE63HF20	63-F	4-20 (ER32)	63	38	50	69	GEA020	
PE63HF26	63-F	4-26 (ER40)	63	38	63	77	GEA026	
PE63HF26100	63-F	4-26 (ER40)	63	38	63	100	GEA026	
PE100HF26	100-F	4-26 (ER40)	100	60	63	85	GEA026	

**MINI (MAX 25000 RPM)**

N.Cod	HSK	d1	D	D1	d2	l1	B	Note
PE63HF07150	63-F	1-7 (ER11)	63	38	19	150	GEX007	
PE63HF10150M	63-F	1-10 (ER16)	63	38	22	150	GEB010	Ghiera Mini
PE63HF13150	63-F	1-13 (ER20)	63	38	35	150	GEX013	
PE63HF16	63-F	3-16 (ER25)	63	38	42	70	GEA016	
PE63HF16090	63-F	3-16 (ER25)	63	38	42	90	GEA016	
PE63HF16150	63-F	3-16 (ER25)	63	38	42	150	GEA016	