

RIGHT ANGLE HEAD

AGGREGATO

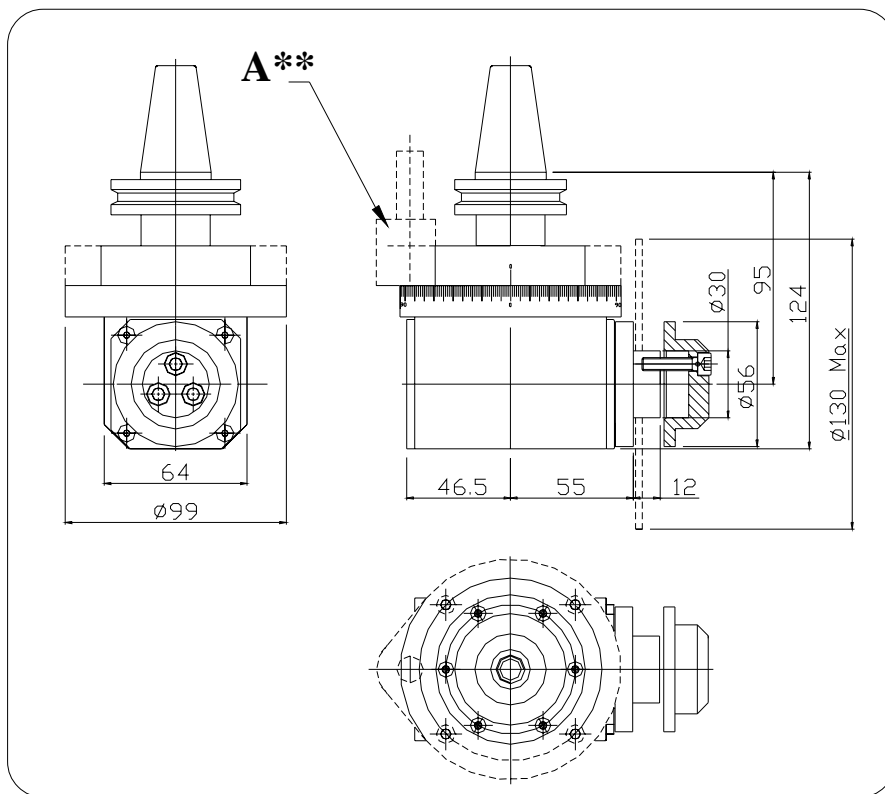

Cod: **WDB30DF30...**

Cod: **WDB30DF30...**

- RPM Max 12000
- Ratio: 1/1
- Weight: Kg. 3,000

- Velocità massima: 12000 giri/min
- Rapporto di trasmissione: 1/1
- Peso: Kg. 3,000

A** Adapter / Adattatore
(HSD-BIESSE)

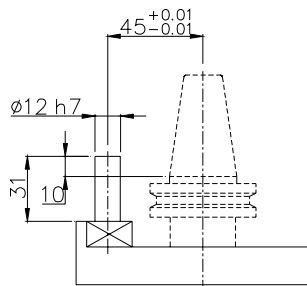

Cod: **WDB30DF3001**

A** Adapter / Adattatore
(BUSELLATO)

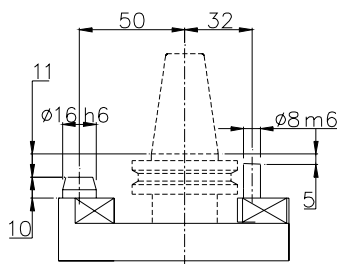

Cod: **WDB30DF3004**

A** Adapter / Adattatore
.....

- Special Adapters on request.
- A richiesta forniamo Adattatori a disegno.