

**COLLET CHUCK (Balanced)**  
**MANDRINS A' PINCES (Balancè)**

**PORTAPINZE (Bilanciato)**

Collets DIN 6499 (ER)  
 Spannzangen DIN 6499 (ER)  
 Pinces DIN 6499 (ER)  
 Pinze DIN 6499 (ER)

**SPANNZANGENAUFNAHMEN (Balanciert)**  
**MANDRILES PORTAFRESAS (Balanzado)**

**STANDARD**

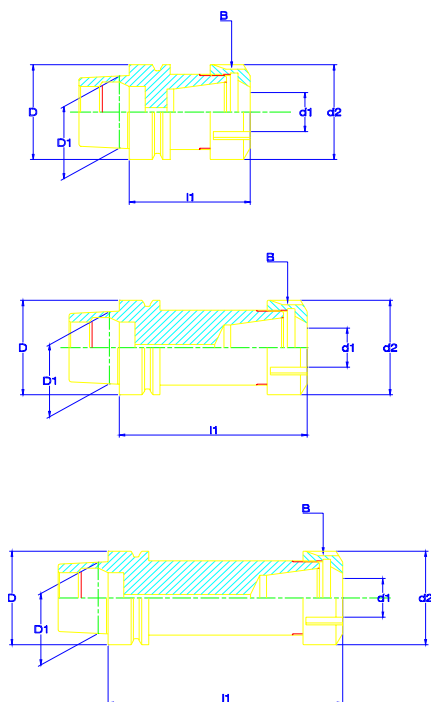

**MINI**

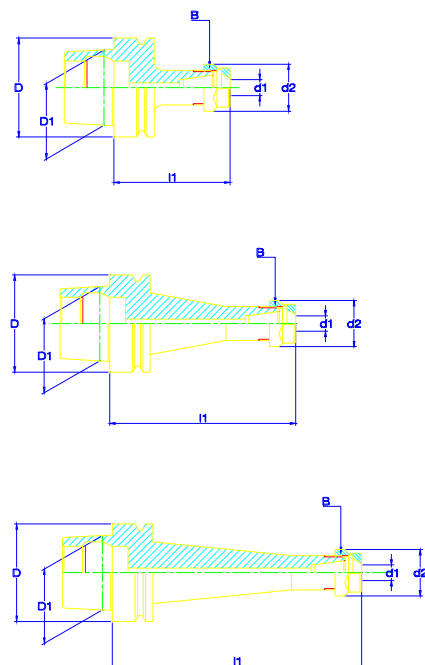

**STANDARD (MAX 25000 RPM)**

N.Cod	HSK	d1	D	D1	d2	l1	B	Kg	Note
PE40HE16	40-E	3-16 (ER25)	40	30	42	75	GEA016	0,8	
PE40HE1650	40-E	3-16 (ER25)	40	30	42	50	GEA016	0,7	
PE40HE16100	40-E	3-16 (ER25)	40	30	42	100	GEA016	0,9	
PE50HE16	50-E	3-16(ER25)	50	38	42	75	GEA016	0,9	
PE50HE20	50-E	4-20 (ER32)	50	38	50	75	GEA020	1,0	
PE50HE20100	50-E	4-20 (ER32)	50	38	50	100	GEA020	1,3	
PE63HE20	63-E	4-20 (ER32)	63	48	50	75	GEA020	1,6	
PE63HE20100	63-E	4-20 (ER32)	63	48	50	100	GEA020	1,9	
PE63HE26	63-E	4-26 (ER40)	63	48	63	77	GEA026	2,4	
PE63HE26100	63-E	4-26 (ER40)	63	48	63	100	GEA026	2,7	

**MINI (MAX 25000 RPM)**

N.Cod	HSK	d1	D	D1	d2	l1	B	Kg	Note
PE40HE07100	40-E	1-7 (ER11)	40	30	19	100	GEA007	0,8	
PE40HE10100	40-E	1-10(ER16)	40	30	32	100	GEA010	0,9	
PE50HE07100	50-E	1-7 (ER11)	50	38	19	100	GEA007	0,9	
PE50HE07160	50-E	1-7 (ER11)	50	38	19	160	GEA007	1,2	
PE50HE10	50-E	1-10 (ER16)	50	38	32	75	GEA010	0,85	
PE50HE10100	50-E	1-10 (ER16)	50	38	32	100	GEA010	0,9	
PE50HE10160	50-E	1-10 (ER16)	50	38	32	160	GEA010	1,2	
PE50HE13	50-E	1-13 (ER20)	50	38	35	75	GEA013	0,9	
PE50HE13100	50-E	1-13(ER20)	50	38	35	100	GEA013	1,1	
PE63HE10100	63-E	1-10 (ER16)	63	48	32	100	GEA010	2,2	
PE63HE10160	63-E	1-10 (ER16)	63	48	32	160	GEA010	2,4	